



Water pH Measurement Instrument for Aquaculture using Titration Methods

Kurnia Illahi^{1,*}, Yohandri¹, Fajar Mukharom Darozat²

¹ Department of Physics, Padang State University 25131, Indonesia

² eFishery Research and Innovation Department 40262, Indonesia

Article History

Received : June, 08th 2024

Revised : June, 26th 2024

Accepted : June, 27th 2024

Published : June, 30th 2024

DOI:

<https://doi.org/10.24036/jeap.v2i2.51>

Corresponding Author

*Author Name: Kurnia Illahi

Email: kurniaillahi0919@email.com

Abstract: Indonesian aquaculture is one of the activities supporting production and economic activities in the fisheries sector locally and nationally. The endurance of the fish body is very dependent on the quality of the water used. One of the water quality parameters is the degree of acidity (pH). The problem in measuring the pH of water is the limited use of the pH meter sensor because the sensor probe must be cleaned regularly. One solution to overcome this problem is to make a water pH measuring instrument for aquaculture using the titration method. This tool is designed to make it easier for aquaculture farmers to measure the pH quality of water without touching the fish pond water. Research was conducted to determine the tool's design and performance specifications. The performance specifications of the water pH measuring instrument consist of mechanical design and electronic design. The results of the color reading of the pH value of the device can be displayed on a serial monitor through the Arduino IDE application or the Bluetooth terminal serial application on Android. The design specifications of the water pH measuring instrument consist of the accuracy and accuracy of the measurement of the pH value of water with the following details: The average pH value reading error is 1.027% with an average accuracy of 98.973% and an average accuracy of 99.419%.

Keywords: fishery, titration, pH of the water.



Journal of Experimental and Applied Physics is an open-access article licensed under a Creative Commons Attribution ShareAlike 4.0 International License which permits unrestricted use, distribution, and reproduction in any medium, provided the original work is properly cited. ©2023 by author.

1. Introduction

Indonesia is the largest archipelago with more ocean than land. Indonesia has more than 17,000 islands and its sea area covers 5.8 million km² or about 70% of the total area of Indonesia [1]. The vastness of Indonesia's oceans has abundant water resources in various regions. Abundant water resources are a business opportunity for the people of Indonesia, one of which is the fisheries sector. The potential of Indonesia's fisheries sector is the largest in the world, both capture fisheries and aquaculture [2]. Aquaculture is one of the activities that support production and economic activities in the fisheries sector both locally and nationally. Aquaculture is currently developing due

How to cite:

K. Illahi, Yohandri, and F.M. Darozat, 2024, Water pH Measuring Instrument for Aquaculture using Titration Method, *Journal of Experimental and Applied Physics*, Vol.2, No.2, page 15-26. <https://doi.org/10.00234/jeapdoi.v1i1.234> 15

to the increasing demand for fish for consumption. Aquaculture needs to be improved to meet the needs of animal protein needed by the community [3]. Therefore, there are supporting factors that influence the growth of aquaculture.

Several factors affect the growth of aquaculture, including; 1) Quality feed will provide good fish growth. Feed with a protein content that is balanced with the needs of fish is needed; 2) The environment consists of water quality that affects the endurance of the fish body. Each type of fish has different water quality parameters, and; 3) Genetics, seed quality greatly affects the quality of fish that will be produced [4]. Therefore, factors that affect the growth of aquaculture need to be considered to improve the quality of aquaculture production.

The productivity and survival of aquatic animals are strongly influenced by physical factors that become water quality parameters in aquaculture [5]. Water quality parameters are not only measured in terms of chemical pollution but several other parameters are very influential [6]. Some parameters include temperature, pH, dissolved oxygen (DO), salinity, ammonia, nitrite, and phosphate organic matter [7]. Aquaculture needs careful attention to water quality. Water quality is important because the entire life cycle of biota takes place in water [8]. Research shows that about 60-70% of fish losses are caused by poor water quality management. About 80% of aquaculture still uses traditional methods in managing water quality. Water quality problems in aquaculture are problems that require special attention [9]. Therefore, farmers must monitor water quality parameters because water quality is an important factor in aquaculture.

Water quality is the condition of water measured and tested with certain parameters and methods based on applicable laws and regulations. Based on the Water Quality Standards of PP No. 82 of 2001 concerning Water Quality Management and Water Pollution Control (Class II), the Acidity Degree (pH) suitable for freshwater fish farming activities ranges from 6 to 9. While the ideal pH for the life of freshwater biota is 6.8 to 8.5. A very low pH causes greater solubility of metals in water so that it can be toxic to aquatic organisms and vice versa, a high pH can increase the concentration of ammonia in water which can be toxic to aquatic organisms [10]. The pH concentration can affect the life of aquatic biota because it will have an impact on the life of microorganisms. Acidic waters tend to cause death in fish [11]. One way to determine the pH concentration of water is to use acid-base titration.

In previous research, Indartono et al. (2020) monitored water quality in aquaculture using a pH meter sensor. However, the pH sensor probe should be cleaned regularly due to the presence of impurities from pond water which results in less effective performance of the sensor used. So long-term sensor use will affect the measurement results. Based on these limitations, this research will automatically make a pH-measuring instrument for aquaculture. The sensor in this designed tool does not directly touch the pond water so that pond water impurities can be overcome and do not affect the measurement results later.

In another study, Wibisono et al. (2019) used a pH sensor to determine the quality of water pH levels using CaCO_3 liquid to increase water pH levels and add H_2O_2 to reduce water pH levels using the acid-base titration method. However, the titration mixing process that occurs is uneven because it is carried out directly in the fish pond. Based on these limitations, this research makes a tool to measure the quality of water pH using the titration method automatically. Measuring the pH of water using the acid-base titration method is carried out in a water container so that the titration mixing process is evenly distributed. Acid-base titration theory is one of the implementing methods that can determine the pH value based on color changes [12].

In volumetric analysis, titration is a process where a standard solution can react when mixed with another solution of unknown concentration until it reaches an equivalence point or endpoint [13]. An acid-base titration is an applied method that can determine pH based on color changes [12]. To determine the pH of a solution can be determined using a pH indicator or acid-base indicator. A pH indicator is a substance that changes color if there is a change in the pH of its environment [14]. Bromthymol blue indicator which has a pH range of 6 to 7.6 [15].

There are several ways used to measure the pH of a solution including using litmus paper, using a universal indicator, using a pH meter, or using a calculation of the concentration of the solution. Each method of measuring the pH of a solution has its advantages and disadvantages [3]. Universal indicator solution is an acid-base indicator solution that shows some subtle color changes in the pH range between 1 to 14 to indicate the acidity or basicity of the solution. This solution is red, but if mixed with another liquid a few drops, the color will change according to the pH color of the liquid. This color change will be detected by the TCS34725 sensor which will then be obtained by the microcontroller to detect the resulting color. In this universal indicator solution, there is a Bromthymol blue indicator that has a pH range of 6.0 to 7.6 where this indicator has a pH range that matches the pH of water for aquaculture.

The color sensor is one of the RGB light-emitting digital color sensing sensors. The RGB sensor can independently detect the intensity of red, green, and blue colors and can measure their brightness values. The color sensor will achieve its value by using an RGB filter on its input. The TCS34725 color sensor has high sensitivity and an IR block filter that helps detect ambient light well [16]. The output of this sensor is a square wave (duty cycle) frequency that is directly proportional to the light intensity [2]. In addition, a peristaltic pump is also needed to move the solution and know the discharge.

Peristaltic pumps are a type of positive displacement pump used to pump various fluids. One of the parameters used in choosing the type of pump is the discharge. Discharge is the volume of fluid moved by the pump from the suction side to the discharge side every unit of time. Discharge can also be interpreted as the speed of fluid flow in the area through which it passes (Maryanto, et al., 2018). Peristaltic pumps work with pressure and displacement. This pump uses undulating movement in an elastic hose to generate pressure and fluid flow [17].

Currently, fish farmers use pH meters to measure the pH of pond water. A general problem when using a pH Meter is that the sensor probe must be cleaned regularly after use, thus limiting the use of the pH meter sensor. One solution to overcome this problem is to make a water pH measuring instrument for aquaculture using the titration method. This tool is designed to make it easier for aquaculture farmers to measure the pH quality of water without touching the fish pond water. Research was conducted to determine the tool's design and performance specifications.

2. Materials and Method

This research is included in the type of engineering research that has six steps of research procedures: ideas and task clarity; conceptual design; arrangement, geometry, and function; detailed design; creation of modeling tools; and testing [18]. The quantities included in the data in this study are the RBG value, duty cycle, liquid depth, pH meter value, error, accuracy, and precision of the pH measuring instrument. This pH measuring instrument will use several electronic components such as NodeMCU ESP32 microcontroller, peristaltic pump, DC pump, and TCS34725 sensor. At

the arrangement, geometry, and function stage, all components of the designed system will be arranged geometrically based on their function. The geometric arrangement of the block diagram of the water pH measuring instrument can be seen in Figure 1.

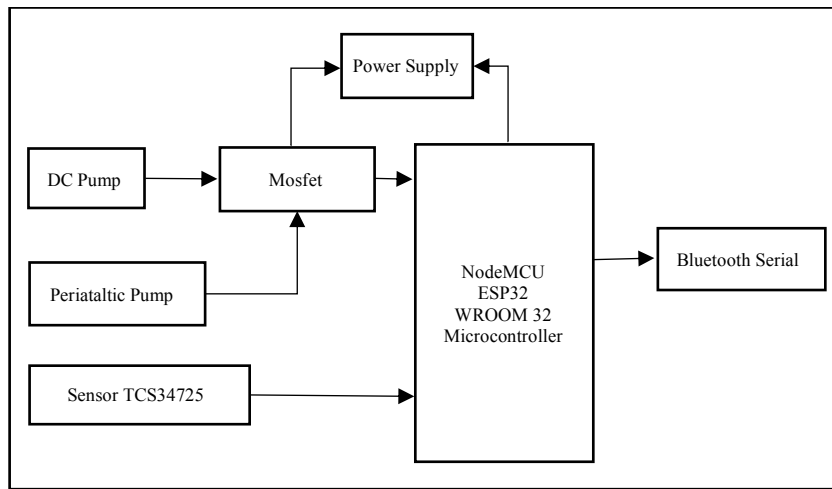

Figure 1. Block diagram of water pH measuring instrument

In Figure 1. Peristaltic pumps are used to regulate the flow rate from the indicator tube and sample tube to the titration tube. The DC pump is used to regulate the discharge of the titration liquid that has been completed. the colour sensor used is the TCS34725 sensor which functions to detect colour and read RGB values. These components will be processed and processed by the NodeMCU ESP32 Microcontroller. The results of reading the pH value of water will appear on the Serial Bluetooth Terminal.

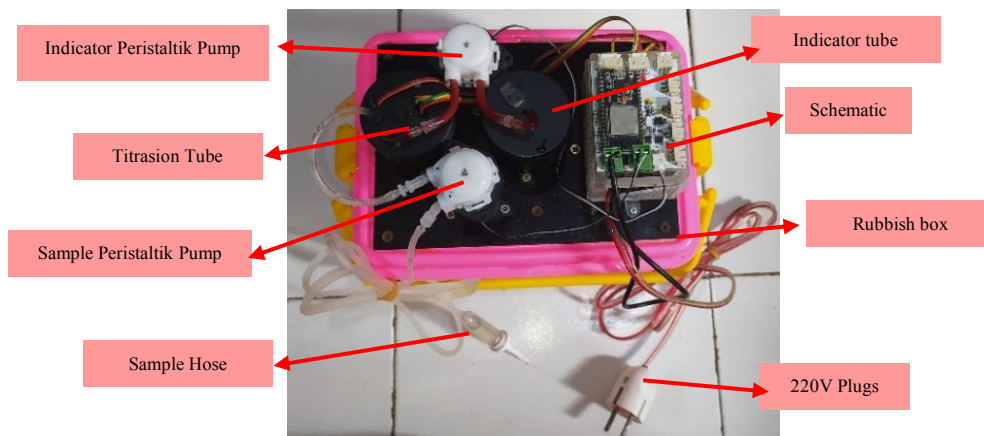

Figure 2. Design of a water pH measuring device

Based on Figure 2. it can be seen that the initial design of the water pH measuring instrument consists of a circuit box, sample box, drain box, titration tube, and indicator tube. In the tool design, there are two peristaltic pumps and one DC pump. INTLLAB peristaltic pump is used to control the discharge of the universal indicator solution. LEIRONG peristaltic pump is used as a sample discharge controller. The DC pump functions as a liquid drain valve after the titration process is complete. The entire circuit is controlled by a NodeMCU ESP32 microcontroller.

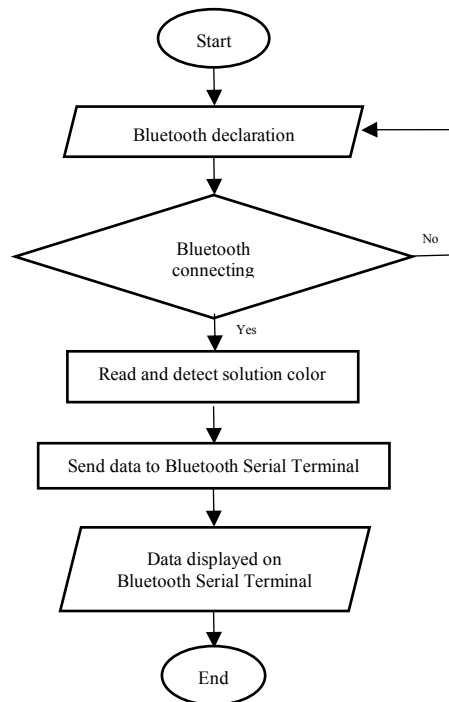

Figure 3. Flowchart of the Microcontroller Design

Based on the flowchart Figure 3, the first step is to connect the NodeMCU ESP32 Bluetooth with the Bluetooth Serial Terminal application for Android. After the Bluetooth is connected, RGB data, estimated pH and residue values will appear on the Android display.

Data collection techniques and tool performance testing include the accuracy and accuracy of the tool. In this study, RGB parameters, duty cycle, liquid depth, and water discharge by looking at the data read by the microcontroller through the serial monitor in the Arduino IDE program or the Bluetooth serial terminal in the Android application. Furthermore, the second test data collection is determining the pH value of water by the prototype and comparing the results with standard measuring instruments (pH Meter) to ensure the accuracy of the tool's work. But before testing, several components must be characterized to improve the accuracy and consistency of measurements on the TCS34725 sensor and Peristaltic Pump. After the characterization process is implemented in the measuring instrument, then testing the tool is carried out by collecting data from the trial results and analyzing the experimental data to get conclusions from the measurement system.

3. Results and Discussion

Based on the experimental results and data analysis that has been carried out, both through scatter diagram representation and statistical calculations, the research results are obtained by the research objectives. The research results are in the form of performance specifications and design specifications. Performance specifications are determined by identifying the function of the components that make up the water pH measuring instrument for aquaculture. Design specifications are determined from the results of testing and data analysis on water pH measuring instruments for aquaculture.

Performance specifications consist of making mechanical devices, electronic circuits, peristaltic pump characteristics, and TCS34725 sensor reading tests. This mechanical device was successfully developed and produced a measuring instrument that can measure the pH value of water automatically, especially for aquaculture. This tool is equipped with a drain box to accommodate titration waste. This tool consists of an electronic circuit that can measure the pH of water accurately and with high accuracy. In this tool, there is a circuit box containing NodeMCU ESP32, TCS34725 sensor, peristaltic pump, 12V DC pump, power supply, and several other small electronic components. All of these measurement results are displayed through the Bluetooth Serial Terminal application on Android which is connected via Bluetooth. This shows that the water pH measuring instrument for aquaculture is a tool that can detect and know the pH condition of the water from a fish pond, in other words fulfilling the function of a Bluetooth-based water pH control and monitoring system with NodeMCU ESP32 [19].

The first experiment was conducted to determine the relationship between RGB values and light intensity using the TCS34725 sensor. Based on the results of the TCS34725 sensor reading test against variations in light intensity, a graph is obtained as shown in Figure 4 below.

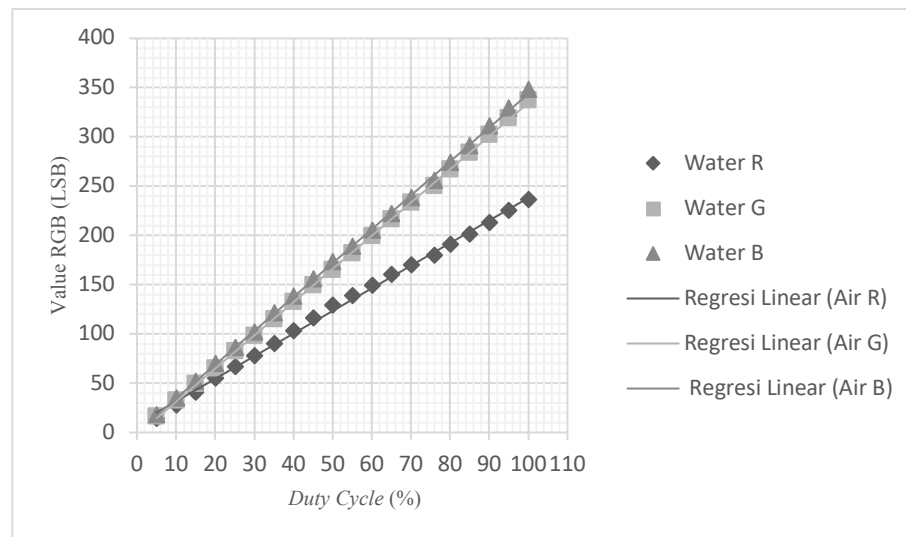

Figure 4. TCS34725 sensor as a function of duty cycle on the distilled water tube

From the scatter diagram (Figure 4), it can be seen that the duty cycle condition when the tube contains distilled water is directly proportional to the RGB value. The higher the duty cycle value, the greater the RGB value produced. This is because the output of the TCS34725 sensor is a square wave (duty cycle) frequency which is directly proportional to the light intensity [20].

Then testing was carried out to determine the characterisation of the peristaltic pump. This experiment was conducted by varying the duty cycle in three different states, namely when $t = 2s$, $t = 5s$, and $t = 10s$. The purpose of this experiment is to determine the liquid discharge by varying the duty cycle. The results of this experiment are represented in the form of a scatter plot which can be seen in Figure 5.

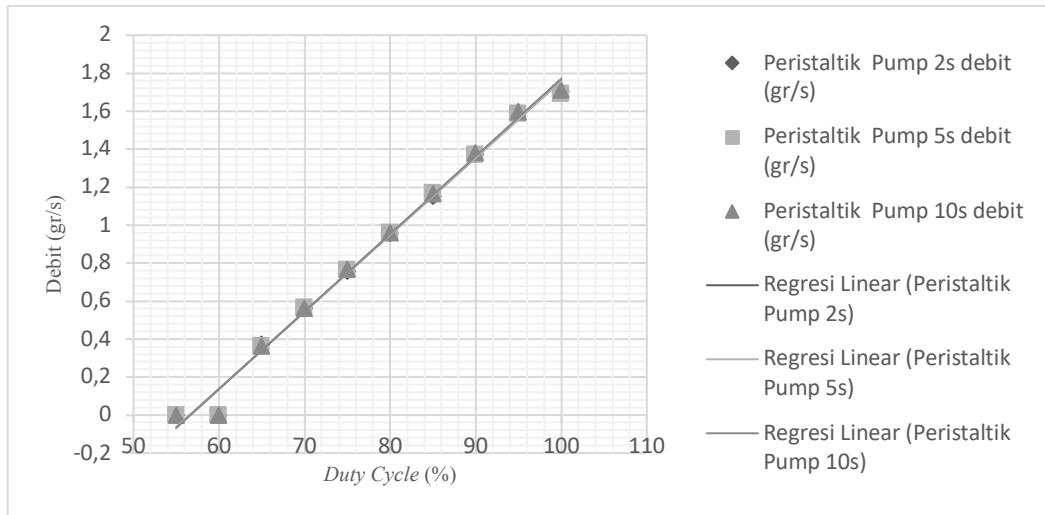

Figure 5. Relationship between duty cycle and water discharge in sample peristaltic pump

Based on the graph (Figure 5), it can be seen that the duty cycle range of 55% - 100% is proportional to the sample water discharge. Where at 90% duty cycle, with the smallest relative error of 0.328711%. The characteristics of peristaltic pumps for sample water show that the higher the duty cycle percentage, the greater the sample water discharge value [21]. Based on the calculation, the sample water discharge is obtained at 1.407 g/s with a relative error of 0.66%.

Next, the TCS34725 sensor reading test was carried out on the depth of the liquid to know the minimum and maximum depth of RGB value reading by the TCS34725 sensor. This experiment was carried out using a duty cycle of 90%. The results of the experiment are represented in the form of a scatter plot which can be seen in Figure 6.

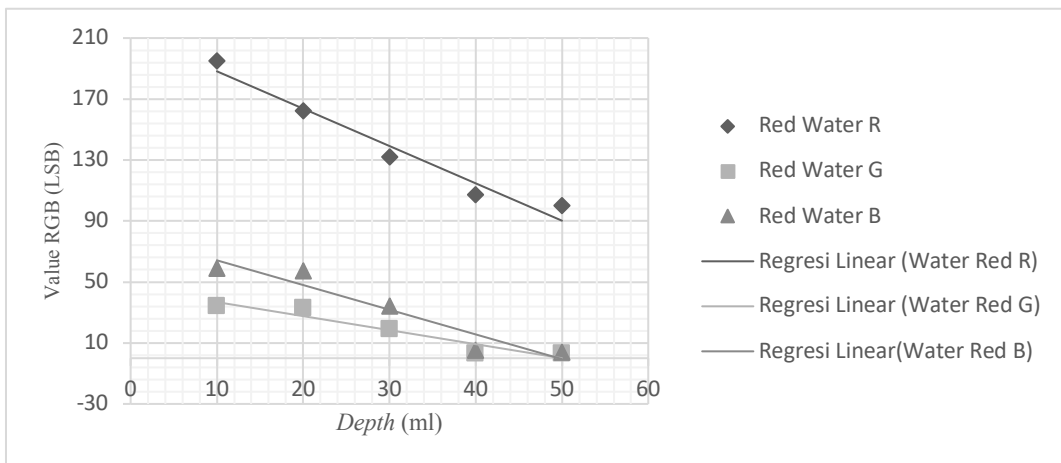

Figure 6. Relationship between the change of liquid depth and RGB value under the condition of red water tube

In the graph (Figure 6), it can be seen that the RGB value is more constant at a water depth of 40 ml. This proves the ability of the TCS34725 color sensor to read RGB values well with a liquid depth of 40 ml. Therefore, in this research, the depth of liquid used is 40 ml so that the color sensor can detect and read colors optimally.

Then the TCS34725 sensor experiment was carried out on the pH of the water. This experiment was carried out by adjusting the pH value of water using a pH meter sensor to get the desired pH value. After that, give 0.2 ml of indicator solution with 40 ml of sample liquid. Then the color sensor reads the RGB value on the titration tube. The characterisation results are represented in the form of a graph which can be seen in Figure 7.

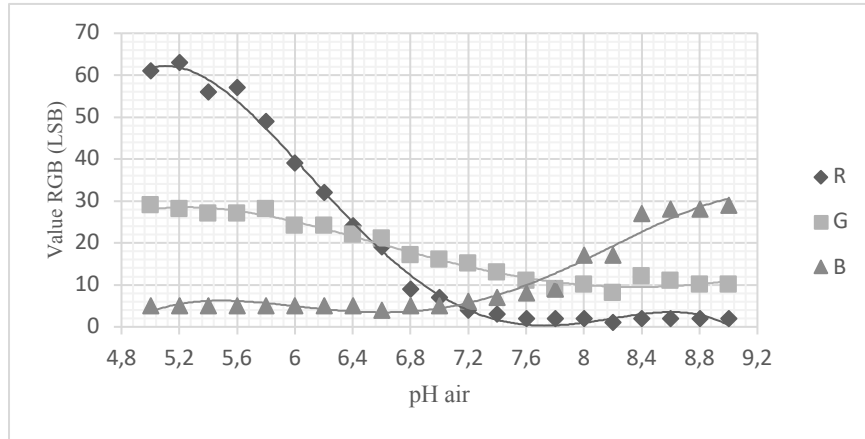

Figure 7. Relationship between color sensor RGB values and pH values

Based on the graph (Figure 7), it forms a 4th-order polynomial function pattern. The graph shows that the lowest pH value is pH 5 where the RGB value of red (R) is higher than green (G) and blue (B) and produces a yellowish-red liquid color. Meanwhile, the highest pH value is pH 9 where the RGB value of blue (B) is higher than green (G) and red (R), and produces a blue liquid color. This is by the pH trajectory in changing the indicator value from acid to base, where a weak acid with a low pH value changes the color of the indicator to a yellowish-red color and a weak base with a high pH value changes the color of the indicator to a blue color [15].

After the 4th-order polynomial regression function is obtained, then the ESP32 firmware adds a pH estimation algorithm based on the RGB reading results from the TCS34725 color sensor. The measurement results of the estimated value of the tested device against the pH Meter reading results can be seen in Table 4.

Table 1. The measurement results of the estimated value of the device are tested against pH Meter reading results

Percobaan ke-	pH Meter	pH Alat	Selisih	Ketepatan
1	6,1	6,1	0	100,0000
2	6,4	6,39	0,01	99,8438
3	6,5	6,41	0,09	98,6154
4	6,6	6,6	0	100,0000
5	6,7	6,75	0,05	99,2537
6	6,8	6,67	0,13	98,0882
7	7,2	7,15	0,05	99,3056
8	7,3	7,13	0,17	97,6712
9	7,5	7,5	0	100,0000
10	7,8	7,63	0,17	97,8205

Based on Table 1. the results of the trial data show that the difference in pH measurement results is greatest at a pH difference of 0.17 with a pH Meter of 7.3 and 7.8 with a measurement accuracy of 97.8205%. The pH value of the tool tested with the same pH meter (Difference: 0) is at pH 6.1; 6.6; and 7.5 with 100% measurement accuracy. This proves that the value between the pH of the tested tool has a pH value that is almost the same as the pH meter.

Design specifications are often also called product specifications. Product specifications are a measure that describes the standards or criteria that must be achieved by a product and how a product works [22]. Design specifications include the accuracy and precision of the measurement of water pH measuring instruments for aquaculture. This accuracy is seen from the comparison of pH readings from measuring instruments with pH meters. The results of the accuracy test are represented in graphical form in Figure 8.

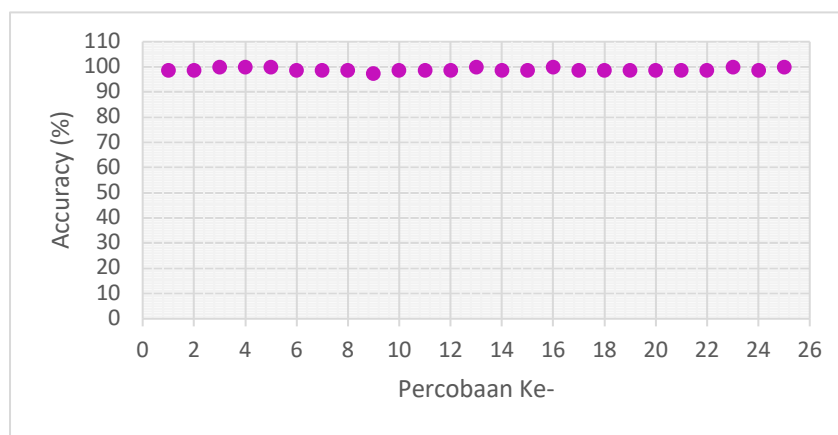

Figure 8. Accuracy of water pH measurement tools for aquaculture

Based on the graph (Figure 8), it can be seen that the accuracy of reading the pH value is good by producing a straight line. The results of the analysis of experimental data, as many as 25 repeated measurements obtained the average percentage of pH value reading error is 1.027% with the lowest percentage accuracy is 97.297%, while the highest percentage accuracy reaches 100%. The average reading accuracy of the water pH measuring instrument is 98.973%. The results of performance testing show that the accuracy of parameter readings on the Water pH measuring instrument for aquaculture functions properly and provides accurate readings.

The precision of the water pH measuring instrument is the accuracy of reading the pH value of water. This accuracy is seen from the approach of the pH value of water to the results of repeated measurements. The expected result of this test is that the repeated measurement value does not change and remains the same. The results of the precision test are represented in graphical form in Figure 9.

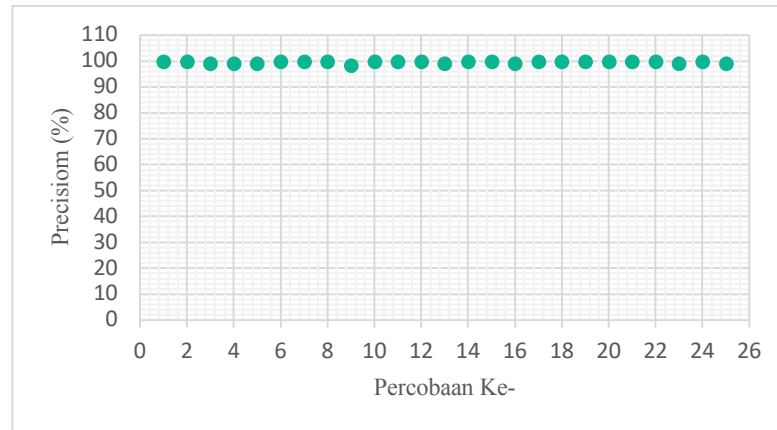

Figure 9. Accuracy of water pH measuring instrument for aquaculture

Based on the graph (Figure 9), it can be seen that the precision of the water pH measuring instrument is good by producing a straight line. The results of experimental data analysis, as many as 25 times repeated measurements obtained the average percentage of pH value reading error is 1.027% with the percentage of precision of water pH readings on the lowest tool is 98.307%, while the highest percentage of accuracy reaches 100%. The average precision of the water pH measuring instrument is 99.419%. The results of the performance test show the accuracy and precision of parameter readings on the Water pH measuring instrument for aquaculture is more than 70%, meaning that the pH measuring instrument works well and provides accurate readings [23].

This water pH measuring instrument for aquaculture has advantages and disadvantages. This tool uses Bluetooth based on Android applications has solved the problem according to the background that has been described. This tool has been able to detect the pH value of water by the actual measuring instrument. This makes it easier for users to use this tool from a certain distance. This tool can be further developed by measuring the pH value of several fish ponds simultaneously by adding a peristaltic pump to the sample water. The disadvantage of this tool is that the system is connected via Bluetooth, so it can only be accessed from a distance of approximately one metre.

4. Conclusion

Based on the results of testing, data analysis, and discussion of the design of a water pH measuring instrument for aquaculture using the titration method, several conclusions can be stated from the research, namely:

1. The performance specification of the design of a water pH measuring instrument for aquaculture using the titration method consists of two parts, namely the design of the mechanical system and the design of the electronic system. The mechanical system design consists of a circuit box, sample box, drain box, titration tube, indicator tube, peristaltic pump bracket, and electronic component connecting cables. The electronic system design consists of a system constituent circuit that includes NodeMCU ESP32 components, TCS34725 sensors, peristaltic pumps, DC pumps, MOSFET modules, RGB LEDs, and power supplies. The results of the color reading of the pH value of the device can be displayed on a serial monitor through the Arduino IDE application or on the Bluetooth Serial Terminal application on Android.

2. The design specifications of the water pH measuring instrument using the titration method consist of two parts, namely the accuracy and precision of the measurement of the pH value of water with the following details: The average percentage error of pH value reading is 1.027% with an average accuracy of 98.973% and an average precision of 99.419%.

References

- [1] I. M. Ali And L. Yudho, "Strategi Pertahanan Laut Dalam Menghadapi Ancaman Keamanan Maritim Di Wilayah Laut Indonesia," *Jurnal Strategi Pertahanan Laut*, Vol. 6, No. 2, Pp. 169-189, 2021.
- [2] M. F. Arianto, "Potensi Wilayah Pesisir Di Negara Indonesia," *Jurnal Geografi*, Vol. 10, No. 1, Pp. 204-215, 2022.
- [3] R. S. Wibowo And M. Ali, "Alat Pengukur Warna Dari Tabel Indikator Universal pH Berbasis Mikrokontroler Arduino," *Jurnal Edukasi Elektro*, Vol. 3, No. 2, Pp. 99-109, 2019.
- [4] N. K. Mahardhika, S. Rejeki And T. Elfitasari, "Performa Pertumbuhan dan Kehidupan Benih Ikan Patin (*Pangasius hypophthalmus*) Dengan Intensitas Cahaya Yang Berbeda," *Journal Of Aquaculture Management Ang Technology*, Vol. 6, No. 4, Pp. 130-138, 2017.
- [5] Siswanto, D. Sofiani And M. S. Hanifa, "Kajian Fisika Kimia Perairan Danau Bangkai Sebagai Dasar Pengembangan Budidaya Ikan," *Rekayasa*, Vol. 14, No. 2, Pp. 245-251, 2021.
- [6] K. Indartono, B. A. Kusuma And A. P. Putra, "Perancangan Sistem Pemantau Kualitas Air Pada Budidaya Ikan Air Tawar," *Joism: Jurnal Of Information System Management*, Vol. 1, No. 2, Pp. 11-17, 2020.
- [7] T. Mujtahidah, D. N. Sari, D. U. Putri, M. C. Mainassy, I. Ode, M. A. Yusuf, R. Retno And L. F. Mulyani, *Budidaya Perikanan*, Tohar Media, 2023.
- [8] Y. Koniyo, "Analisis Kualitas Air Pada Lokasi Budidaya Ikan Air Tawar Di Kecamatan Suwawa Tengah," *Jurnal Technopreneur (Jtech)*, Vol. 8, No. 1, Pp. 52-58, 2020.
- [9] Y. T. K. Yuniior And Kusrini, "Sistem Monitoring Kualitas Air Pada Budidaya Perikanan Berbasis IoT Dan Manajemen Data," *Creative Information Technology Journal*, Vol. 6, No. 2, Pp. 153-164, 2021.
- [10] D. Ramayanti And U. Amna, "Analisis Parameter COD (*Chemical Oxygen Demand*) Dan pH (*Potential hydrogen*) Limbah Cair Di PT. Pupul Iskandar Muda (PT. Pim) Lhokseumawe," *Quimica: Jurnal Kimia Sains Dan Terapan*, Vol. 1, No. 1, Pp. 16-21, 2019.
- [11] Supriatna, M. Mahmudi, M. Musa And Kusriani, "Hubungan pH dengan Parameter Kualitas Air Pada Tambak Intensif Udang Vannamei (*Litopenaeus vannamei*)," *Jurnal Of Fisheries And Marine Research*, Vol. 4, No. 3, Pp. 368-374, 2020.
- [12] D. A. Wibisono, S. Aminah And G. Maulana, "Rancang Bangun Sistem Monitoring Kualitas Air Pada Tambak Udang Berbasis Internet Of Things," *Repository. Politeknik Manufaktur Bandung*, 2019.
- [13] D. Ika, "Alat Otomatisasi Pengukur Kadar Vitamin C Dengan Metode Titrasi Asam Basa," *Jurnal Neutrino*, Vol. 1, No. 2, Pp. 163-178, April 2009.
- [14] R. T. Padmaningrum, "Titrasi Asidimetri," *Jurnal Pendidikan Kmia*, Pp. 1-9, 2006.

- [15] H. Sulistyarti And A. Mulyasuryani, *Kimia Analisis Kuantitatif Dasar*, Universitas Brawijaya Press, 2021.
- [16] M. D. Utami, A. A. Zahra And Sudjadi, "Perancangan dan Analisa Kinerja Sistem Akuisisi Data Sensor TCS43725 dan Pengendalian Pompa Motor DC Pada Alat Pencampur Warna," *Transient*, Vol. 9, No. 3, Pp. 360-367, 2022.
- [17] S. P. Nugraha And S. W. Purtiningrum, "Rancang Bangun Sistem *Smart Soft Drink* Dispenser Menggunakan Raspberry Pi Berbasis Android," *Ikra-Ith Informatika*, Vol. 5, No. 2, Pp. 75-84, 2021.
- [18] L. Kirkup, *Experimental Methods For Science And Engineering Students An Introduction To The Analysis And Presentation Of Data Second Edition*, Cambridgeshire: Cambridge University Press, 2019.
- [19] F. Hidayat, A. Harijanto And B. Supriadi, "Rancang Bangun Alat Ukur Sistem Monitoring pH dan Suhu Kolam Ikan Lele Berbasis IoT dengan ESP8266," *Jurnal Kumparan Fisika*, Vol. 5, No. 2, Pp. 77-84, 2022.
- [20] B. Ardinata, S. Nurcahyo And B. Priyadi, "Implementasi Algoritma Fuzzy Pada Alat Sortir Kematangan Buah Kopi Berdasarkan Warna Berbasis Arduino Uno," *Jurnal Elektronika Dan Otomasi Industri*, Vol. 7, No. 2, Pp. 79-84, 2020.
- [21] L. E. Maryanto, Basyirun And S. Anis, "Pengaruh Diameter Roller Terhadap Debit Pompa Peristaltik," *Saintekno: Jurnal Sains Dan Teknologi*, Vol. 16, No. 1, Pp. 65-72, 2018.
- [22] W. D. Widiartha, *Rancang Bangun Pyranometer Berbasis IoT Menggunakan Sensor*, Padang: Universitas Negeri Padang, 2022.
- [23] O. Khotimah, D. Darmawan And E. Rosdiana, "Perangkat dan Metoda Kalibrasi Sensor Universal," *E-Proceeding Of Engineering*, Vol. 9, No. 3, Pp. 866-874, 2022.