



# Design And Construction of Air Quality Monitoring System Using NodeMCU IoT-based

Vivi Wulandari<sup>1</sup>, Yohandri<sup>1,\*</sup>

<sup>1</sup> Department of Physics, Universitas Negeri Padang, Padang 25131, Indonesia

## Article History

Received : September, 16<sup>th</sup> 2023

Revised : September, 26<sup>th</sup> 2023

Accepted : September, 26<sup>th</sup> 2023

Published : September, 30<sup>th</sup> 2023

## DOI:

<https://doi.org/10.24036/jeap.v1i2.23>

## Corresponding Author

\*Author Name: Yohandri

Email: [yohandri@fmipa.unp.ac.id](mailto:yohandri@fmipa.unp.ac.id)

**Abstract:** Air as a natural resource affects human life and other natural resources. Air consists of about 78% Nitrogen, 20% Oxygen, 1.07% consists of Neon (Ne), Helium (He), Methane (CH<sub>4</sub>) and Hydrogen (H<sub>2</sub>), 0.9% Argon and the remaining 0.03% Carbon Dioxide (CO<sub>2</sub>). This research is a type of engineering research. Data collection was carried out by direct measurement. For direct data collection, it was carried out by monitoring levels of CO<sub>2</sub>, CO, temperature, and humidity, for data collection from each parameter, 5 variations were given for measurement. Based on the objectives of the research, the results of the design specifications of the tool are obtained, namely the percentage level of accuracy of the average measurement produced by air quality monitoring which is 97.78%, the average percentage of relative error obtained is 2.24%. Therefore, it can be concluded that the specifications for the performance of the tool are that the components that make up the tool can work well.

**Keywords:** Air Quality Monitoring, MQ-135, DHT11, NodeMCU



Journal of Experimental and Applied Physics is an open access article licensed under a Creative Commons Attribution ShareAlike 4.0 International License which permits unrestricted use, distribution, and reproduction in any medium, provided the original work is properly cited. ©2023 by author.

## 1. Introduction

Air as a natural resource affects human life and other living things. Air consists of about 78% Nitrogen, 20% Oxygen, 1.07% consists of Neon (Ne), Helium (He), Methane (CH<sub>4</sub>) and Hydrogen (H<sub>2</sub>), 0.9% Argon and the remaining 0.03% Carbon Dioxide (CO<sub>2</sub>) [1]. The content of carbon dioxide in fresh air and good for breathing varies between 0.03% (300 ppm) to 0.06% (600 ppm) depending on the location [2]. The concentration of carbon dioxide in the atmosphere has increased since the start of the industrial revolution, due to the rapid development of human activities. Scientific facts show that the increasing concentration of CO<sub>2</sub> in the atmosphere causes global changes and climate change which is characterized by an increase in air temperature [5].

## How to cite:

V. Wulandari and Yohandri, 2023, Design and Construction of Air Quality Monitoring System Using NodeMCU IoT-based, *Journal of Experimental and Applied Physics*, Vol.1, No. 2, page 99-112.  
<https://doi.org/10.24036/jeap.v1i2.23>

CO<sub>2</sub> levels 5 % or about 50,000 ppm and 8% or around 80,000 ppm [9]. CO<sub>2</sub> levels by looking at the value of the Air Pollution Standard Index (ISPU). ISPU is a number that does not have units and describes the condition of air quality at a certain location and time [10]. According to the Head of the Padang City Environmental Service (DLH), the air quality in the city of Padang is in the moderate category. The highest number recorded is at a value of 67 with the PM 10 parameter in 2019 [11]. Meanwhile, in 2021, the air quality in the city of Padang is at a value of 78.14. Based on this value, it can be proven that the ISPU index value is increasing. ISPU values can only be accessed in certain places. So that the public cannot access ISPU data freely.

To overcome this problem, a tool that can monitor air quality is needed so that it can be accessed anywhere by everyone. A CO<sub>2</sub> level monitoring tool, was made by [12-13]. This research uses only one sensor, namely MQ-2, so it can only measure CO<sub>2</sub> levels . Meanwhile, the air temperature cannot be measured. The MQ-2 sensor only focuses on measuring methane, butane, and LPG gas in the air. Based on the problems that have been described, in this study an air quality monitoring tool will be developed using two sensors, namely the MQ-135 sensor to detect CO<sub>2</sub>, CO and DHT11 sensors to measure temperature and humidity. The use of these two sensors produces more complete parameters. Besides the MQ-135 sensor and the DHT11 sensor, the air quality monitoring tool is designed using NodeMcu and the Internet of Things. In this tool the Internet of Things (IoT) is useful as a system that combines all devices so that they can be controlled and monitored via the internet. With an air quality monitoring system using an IoT system, any information on the value of CO<sub>2</sub> levels and air temperature can be seen on the website with normal and abnormal indicators.

## 2. Materials and Method

This research is included in engineering research, engineering research, namely design activities that are not carried out routinely, so that there are new contributions, both in the form of processes and products/prototypes. For engineering research, the discussion of design activities in it involves things that are relatively new, if the design activity refers to certain design code standards, then the activity is not an engineering research activity.

Some of the procedures carried out for research include ideas and clarity, conceptual design, functional geometry arrangement, detailed design, prototyping, and testing. The explanation of the research procedure is described as follows: of ideas are obtained by searching for literature studies from various sources such as books, journals, articles and other relevant sources. Variables to be studied, things that have been done and will be done. Through the ideas obtained from the search results from the study of literature, new perspectives for research are obtained. Conceptual designs can be drawn up if ideas for research have been found. Conceptual design is the stage to realize the idea before a system is formed from the research to be made. The form of the system design to be made can be found at the conceptual design stage.

Components for the system to be made are arranged geometrically according to their respective functions based NodeMcu Internet of Things- can be seen in Figure 1.

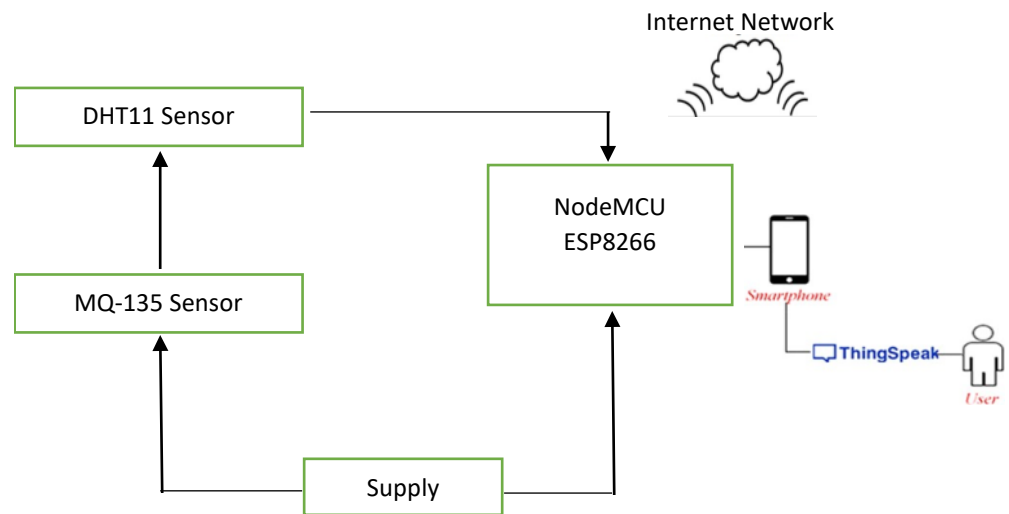

Figure 1. The Air Quality Monitoring System Structure

In this setup, the NodeMcu ESP8266 acts as the central controller, utilizing a voltage source to power the entire system. The MQ-135 sensor serves as a gas sensor, detecting CO<sub>2</sub> and CO levels in the environment. Additionally, the DHT11 sensor functions as a temperature detector. The Internet plays a crucial role in connecting the microcontrollers, smartphones, and all the components together. Users can monitor the CO<sub>2</sub> and CO levels in their surroundings through the ThingSpeak platform, which serves as a monitoring system displaying data on internet websites. The smartphone acts as an interface for users to view and retrieve real-time data directly from Web Thingspeak. Overall, this integrated system enables users to keep a close watch on the air quality and temperature in their environment using ThingSpeak as a monitoring platform. Description of the arrangement of the air quality detection system using IoT-based NodeMcu.

Detailed design for the manufacture of air quality monitoring tools consisting of hardware design and software design. The hardware design is to describe the physical part of the air quality monitoring tool while the software design is useful for hardware instructions to complete the task. The software used to operate the tool is NodeMcu. For programming on the NodeMcu it is supported by the Arduino IDE. The programming language used by NodeMcu is the Lua and system in this tool consists of several electronic components, namely, supply, MQ-135 sensor, DHT11 sensor. The design of the air quality monitoring tool can be seen in Figure 2.

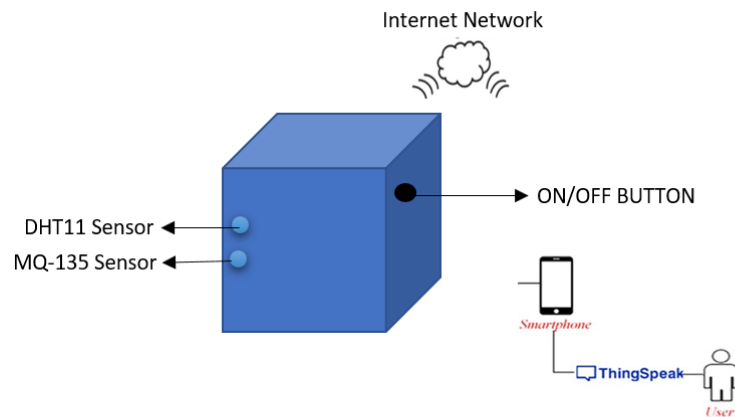

Figure 2. Design of the External Air Quality Monitoring Tool

Figure 2 is the design of the external air quality monitoring tool. Air quality monitoring tool in the form of a box or box. The black button is useful as a button to turn the tool on and off. For the front there is a DHT11 sensor to measure the state of temperature, humidity and an MQ-135 sensor to measure CO<sub>2</sub>. The design of the visible air quality monitoring device can be seen in Figure 3.

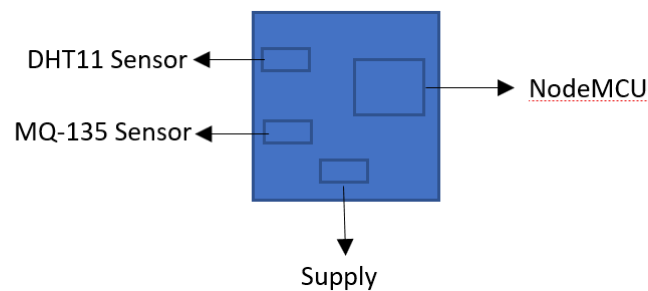

Figure 3. The design of the visible air quality monitoring device

In Figure 3, the design of the air quality monitoring device Inside, there are electronic components. Supply as a voltage source. The MQ-135 sensor will detect levels of CO<sub>2</sub>, CO and the DHT11 sensor will measure the state of temperature, humidity and then sent to the NodeMcu ESP8266 which will process the input data. Before being processed by the NodeMcu ESP8266, it is first connected to WiFi, which is useful when it has been processed by the NodeMcu ESP8266 it will be sent to the output, namely the Web ThinkSpeak. Thingspeak-Web display is an index curve of increasing and decreasing levels of CO<sub>2</sub>, CO and temperature and humidity conditions that appear on the Web ThingSpeak.

Making Air quality monitoring equipment will be made according to the design. The system that has been built will be tested for tools. If the test has been carried out on the tool, then experiments can be carried out in the study. The last stage for engineering research is to test the system that has been created. Tests are carried out to ensure all systems are functioning properly and look for errors in the system.

This study uses data collection techniques through measurement of the physical quantities contained in the system. Data collection techniques in this study are sensor output voltage, measurement data for CO<sub>2</sub>, CO levels, temperature and humidity conditions by sensors, accuracy, and accuracy of the tool. The first data collection technique is to measure the levels of CO<sub>2</sub>, CO

using the MQ-135 sensor. The sensor output data will be in the form of voltage. Giving different levels of CO<sub>2</sub>, CO on the sensor will produce different voltages. The second data is to detect the state of temperature and humidity. Giving different temperatures on the sensor will produce different voltages. The third data is the accuracy of the tool to ensure the accuracy of the work of the tool, a comparison of the CO<sub>2</sub>, CO, temperature, humidity levels data obtained from the tool made with CO<sub>2</sub>, CO content data from standard tools is carried out, if the data obtained is the same as the index range. standard data on a standard tool, then the tool has good accuracy. The fourth data is the instrument accuracy data. The instrument accuracy data is obtained by measuring the levels of CO<sub>2</sub>, CO and the state of temperature, humidity repeatedly.

Data analysis techniques were carried out to obtain conclusions. The data analysis technique that will be carried out in the study is graphically the measured variables. The general technique used to plot data on an XY graph is that the independent variable is plotted on the X axis, while the dependent variable is plotted on the Y axis [14]. Accuracy is the degree of conformity or proximity of a measurement result to the actual price [15]. From this understanding it can be determined the percentage of error in the percentage of error is the percentage of deviation between the measured value and the actual value or the percentage of error. Actual can be interpreted as the actual value measured by standard tools or theoretical calculations, while read is the value measured by the tool made. The accuracy of the measurement is the similarity of the values of a group of measurements. The most likely value of a measurement variable is the average value of the total measurements made. Here X<sub>n</sub> is the value of the nth measurement and n is the total number of measurements. After the measurement data is processed both graphically and statistically, an analysis of the data is carried out to draw conclusions.

### 3. Results and Discussion

Performance Specifications for tool performance are identifying or describing the function of each part forming the system, where it is necessary to test the tool and analyze the tool, so that it can be seen whether the system is working properly. The specifications carried out during the study were the characterization of the MQ-135 sensor and the DHT 11 sensor and the analysis of parameter concentration levels. sensor uses NodeMcu ESP8266 with the aim that the data obtained is real time between the first sensor and the second sensor. The MQ-135 sensor connection circuit can be seen in Figure 4.

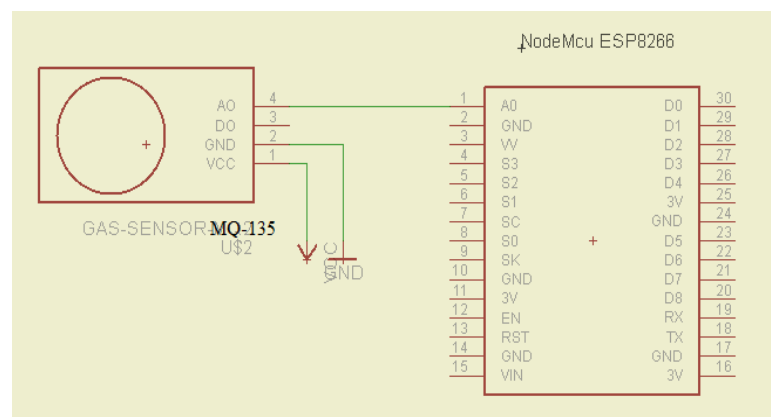

Figure 4. MQ-135 Sensor Connection Circuit

In Figure 4 the MQ-135 sensor has a module with 4 pins. Pin 1 is VCC connected to VCC supply, pin 2 GND is connected to GND supply, pin 3 is D0 is not used because this tool uses A0, and pin 4 is A0 which is connected directly to A0 NodeMcu ESP8266. The four pins are connected to a pin header that connects directly to the NodeMcu ES8266 microcontroller. Characteristics of the DHT11 sensor using NodeMcu ESP8266 with the aim that the data obtained is real time between the first sensor and the second sensor. The DHT11 sensor connection circuit can be seen in Figure 5.

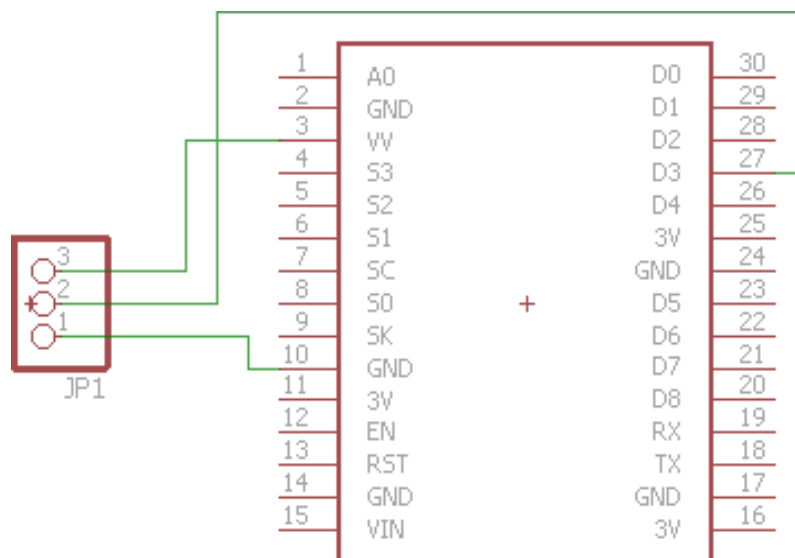

Figure 5. DHT11 Sensor Connection Circuit

In Figure 5 the DHT11 sensor has 4 pins / pins but only 3 pins are used. Pin 1 GND is connected to GND supply, pin 2 is data connected directly to D3 on NodeMcu ESP8266, pin 3 is VCC which is connected to VCC supply. After characterizing the MQ-135 sensor and the DHT11 sensor, the next step is software. Design software is carried out to form instructions that will be used in the tool work system. In designing software , the first thing to do is create a program algorithm. One form of the algorithm is poured in the form of a flowchart as an outline of the course of the program. Flowchart or flow chart is a chart with symbols that describe the sequence of processes in detail and the relationship between a process with other processes in one program. The flowchart of tool design can be seen in Figure 6.

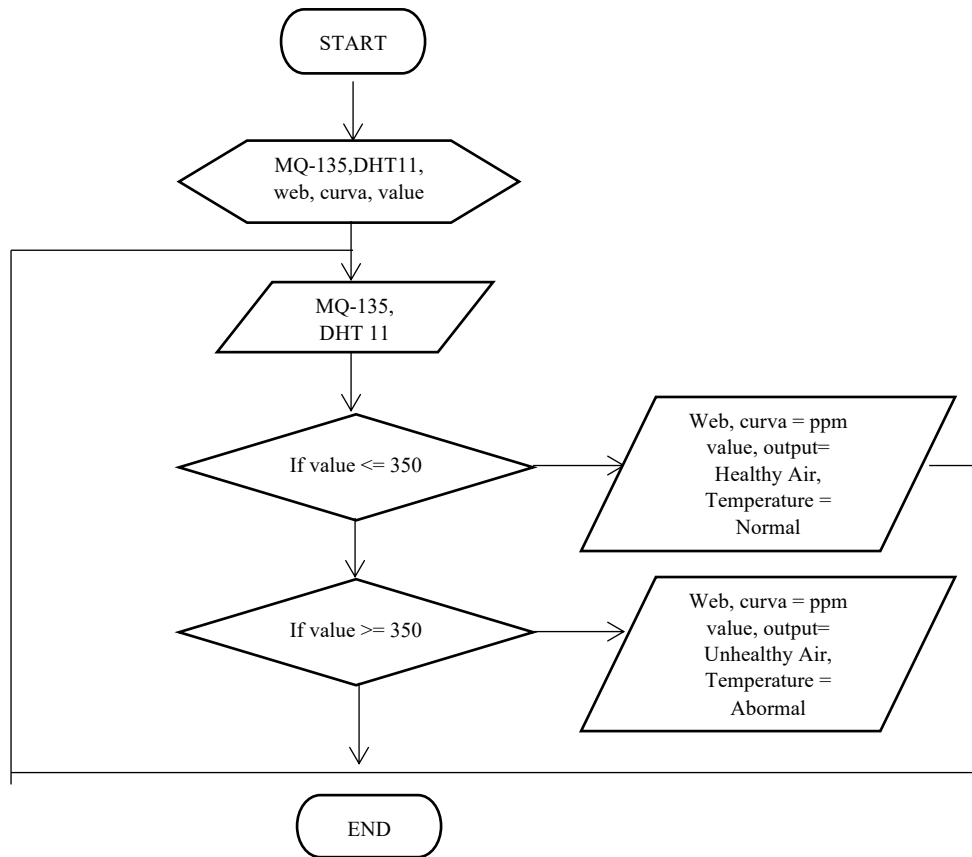

Figure 6. Tool Design Flowchart

In Figure 6 is a flowchart of tool design. Starting with initializing the I/O pins used, namely the MQ-135 sensor and the DHT11 sensor, then reading data from the MQ-135 sensor and DHT11 sensor, for reading the sensor data in the form of CO<sub>2</sub>, CO, temperature, and humidity compounds. The NodeMcu microcontroller is used as a sensor reading process to detect gas and also temperature. If the MQ-135 sensor reads data on CO<sub>2</sub> gas compounds, CO ≤ 350 ppm, then the data on Thingspeak in field 1 and field 2 includes healthy air levels, and in fields 3 and 4 there is normal temperature and humidity state data detected by the sensor. DHT11. If the MQ-135 sensor reads CO<sub>2</sub> gas compound data, CO > 350 ppm, then the data on Thingspeak in field and field 2 includes unhealthy air levels, and in fields 3 and 4 there is data on abnormal temperature and humidity conditions detected by the sensor. DHT11.

Manufacture of air quality monitoring is in the form of a box or box which has a length of 8 cm, a width of 4 cm and a height of 10 cm. In this air quality monitoring tool there is a switch that functions as an ON/OFF on the tool, and there is a small green led light that functions as a marker for the ON/OFF. The mechanics of air quality monitoring can be seen in Figure 7.

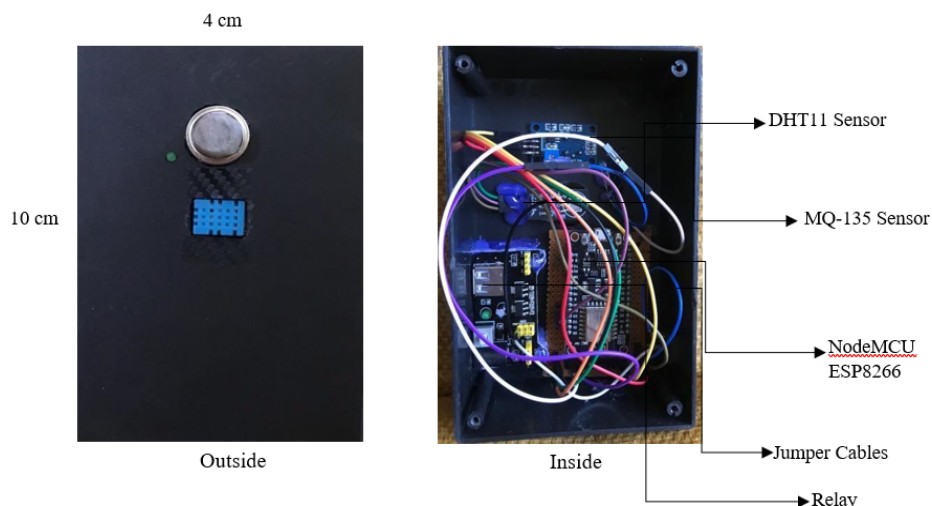

Figure 7. Air quality monitoring mechanics.

In Figure 7 it can be seen that the mechanics of air quality monitoring are visible from the outside and from the inside. Air quality monitoring has a switch on the right side of the tool that functions as an ON/OFF, on the left side there is a connecting plug with the supply, namely the adapter. For the front, the MQ-135 sensor is installed at the top which functions to detect CO<sub>2</sub> levels and CO levels, at the bottom a DHT11 sensor is installed to detect temperature and humidity conditions and between the MQ-135 sensor and the DHT11 sensor there is a small green LED that functions as a marker tool ON / OFF.

How the air quality monitoring tool works starts by connecting the device to the supply, then setting the switch to the ON, the next step is to turn on the hotspot or WiFi, if the NodeMcu is already connected to the hotspot or WiFi then open the ThingSpeak.com, then you can see the data increase and decrease of CO<sub>2</sub>, CO, temperature and humidity levels.

Data obtained on the device are the output voltage data of the MQ-135 sensor and the DHT11 sensor. Sensor output voltage data is needed to identify how sensitive the sensor is. Retrieval of sensor output voltage data by measuring using a multimeter. The first is to measure the output voltage on the MQ-135 sensor. Table 1 is the MQ-135 sensor output voltage data when measuring CO<sub>2</sub>.

Table 1. Output Voltage of MQ-135 Sensor When Measuring CO<sub>2</sub> Levels

Gas Variations in CO <sub>2</sub>	Output Voltage (V)
0.352	4.3
0.704	4.4
1.04	4.6
1.4	4.7
1.72	4.8

Table 1 is output voltage data on the MQ-135 sensor when detecting CO<sub>2</sub>. In Table 1 it can be seen that when the CO<sub>2</sub> gas variation is given to the sensor, the output voltage from the MQ-135 sensor also varies and the value does not exceed 5V. The second measurement is to measure the output voltage of the MQ-135 sensor when measuring CO levels. Output voltage data from the MQ-135 sensor when measuring CO can be seen in Table 2.



Table 2. MQ-135 Sensor Output Voltage When Measuring CO Levels CO

Gas Variations (ppm)	Output voltage (V)
15	4.0
20	4.3
25	4.5
30	4.6
35	4.9

Table 2 is the output voltage data on the MQ-135 sensor when detecting CO levels. In Table 2 it can be seen that when CO gas levels were varied, the output voltage value was also varied, not exceeding 5V. The third measurement was carried out by measuring the output voltage of the DHT11 sensor to measure temperature. Table 3 is the DHT11 sensor output voltage data when measuring temperature.

Table 3. DHT11 Sensor Output Voltage When Measuring Temperature and humidity

Variations (°C)	Output Voltage (V)	Output Voltage (V)
16	3.9	4.3
20	4.4	4.4
24	4.6	4.6
28	4.7	4,5
30	4.7	4.9

Table 3 Is the output voltage data on the DHT11 sensor at when detecting temperature. When measuring the output voltage of the DHT11 sensor, the value varies not less than 3V and not exceeding 5V with the temperature given to the sensor also varying. The fourth measurement is to measure the output voltage of the DHT11 sensor when measuring humidity. The output voltage data from the DHT11 sensor when measuring humidity can be seen in Table 3. Table 3 Is the output voltage data on the DHT11 sensor when detecting humidity. In Table 4 it can be seen that the output voltage of the DHT11 sensor when detecting humidity varies because the temperature given to the sensor also varies.

Accuracy on Air Quality The accuracy of the air quality monitoring tool is obtained from the comparison of parameter levels from standard equipment with tools that have been made. If the parameter level obtained by the standard tool is the same or close to the parameter level on the tool made, the tool is declared accurate. Table 5 is data on the accuracy of CO<sub>2</sub> on air quality.

Table 5. CO<sub>2</sub> Accuracy Data on Air Quality

NO	PPM CO <sub>2</sub> Level (actual)	PPM CO <sub>2</sub> Level (Read)	KR Percentage (%)
1	280	270.83	3.27
2	257	257.44	2.72
3	317	317.82	0.25
4	310.25	311.47	0.39
5	458.15	457.07	0.23
Average	324.48	322.92	1.37

In Table 5 is the accuracy data of the CO<sub>2</sub> level. Parameter In Table 5, it can be seen that the levels of CO<sub>2</sub> that are read by the tool made are not much different from the levels of CO<sub>2</sub> is are

read by standard tools, the average percentage of error obtained when measuring CO<sub>2</sub> levels 1.37%. The results of readings of CO<sub>2</sub> levels by the tools that have been made can be seen in attachment 5.

Furthermore, the accuracy of the CO<sub>2</sub> levels in air quality is measured by comparing the readings obtained from the standard equipment with the readings obtained from the tools made. Table 6 is data on the accuracy of CO on air quality.

Table 6. CO accuracy data on air quality

No	PPM CO levels (actual)	PPM CO levels (read)	KR percentage (%)
1	15	14.60	2.66
2	20	19.46	2.70
3	25.50	25.14	1.41
4	29	28.5	1.70
5	33	32.65	1.06
Average	24.5	24.07	1.90

In Table 6 is the accuracy data of the CO level parameter. In Table 6 it can be seen that the CO levels read by the tool made are not much different from the CO levels read by standard tools and the percentage of error obtained is not large, namely 1.90%. In the state of temperature accuracy is also carried out, by comparing the readings of the temperature state on the standard tool with the temperature state that is read by the tool that has been made. Table 7 is the accuracy of temperature on air quality.

Table 7. Temperature Accuracy Data on Air Quality

NO	Temperature °C (actual)	Temperature °C (read)	Percentage of KR (%)
1	18	17.3	3.88
2	22	21.5	2.27
3	25	26.2	4.8
4	31	32	3.22
5	32	32.6	1.87
Average	25.6	25.92	3.20

In Table 7 is the accuracy of temperature data. In Table 7 it can be seen that the level of the temperature state that is read by the tool made is not much different from the state that is read by the standard tool, the percentage value of the error obtained when making small measurements is 3.20%. The results of readings from the state of the instrument that have been made can be seen in attachment 7.

Measurement of accuracy is also carried out for humidity by comparing the reading of humidity data from a standard tool with the reading of humidity data from the tool that has been made. Table 3 is the accuracy of humidity data on air quality.

Table 8. Humidity Accuracy Data on Air Quality

NO	Humidity %RH (actual)	Humidity %RH (read)	Percentage KR %
1	67	65	2.90
2	61	58	4.90
3	60	59	1.66
4	59	58	1.69
5	57	57.5	1.40
Average	60.8	59.5	2.51

In Table 8 is the accuracy data of the humidity state parameter. In Table 8 it can be seen that the humidity state read by the tool made is not much different from the humidity state read by the standard tool and the error percentage obtained is 2.51%. The results of readings from the humidity state by the tool that has been made can be seen in attachment 8.

Accuracy of air quality monitoring is obtained by measuring the parameters repeatedly. The expected accuracy in air quality monitoring if the measurements are carried out 10 times in the same place and at the same time the results obtained do not change and the measurement results obtained are the same. Table 9 is the measurement accuracy of air quality parameters.

Table 9. Accuracy Data of Air Quality

Experimental	CO levels (ppm)	CO levels (ppm)	Temperature °C	Humidity %RH
1	270.83	25.14	28	51
2	271.40	25.14	28.6	57
3	270, 15	14.80	29.7	55
4	270.83	14.60	29.7	56
5	270.45	19.46	29.4	53
6	270.35	19.46	30.7	53
7	271.15	14.60	30	52
8	257.44	14.80	30	51
9	257.44	14.80	30	51
10	257.44	14.60	30.7	53
Average	266, 74	32.54	29.68	53.2

Table 9 is the result data from accuracy of measurement of air quality parameters. Accuracy data retrieval by measuring repeatedly. It can be seen in Table 9 that the measurement results obtained are almost the same and the relative errors obtained.

Based on the analysis that has been done both graphically and statistically, it provides research results in accordance with the research objectives. The results of the study obtained performance specifications and design specifications for air quality monitoring tools using an IoT-based NodeMcu. Performance specifications have been identified through the identification of the functions of the system-forming parts. System design specifications are known from the results of measurements and data analysis. The first result is the performance specification of the MQ-135 sensor characteristics with NodeMcu. The MQ-135 sensor is a sensor that monitors air quality to detect ammonia gas (NH<sub>3</sub>), sodium dioxide (NO<sub>2</sub>), alcohol/ethanol (C<sub>2</sub>H<sub>5</sub>OH), benzene (C<sub>6</sub>H<sub>6</sub>), carbon dioxide (CO<sub>2</sub>), sulfur gas (H<sub>2</sub>S), carbon monoxide (CO) and other flue gases [16]. The MQ-135 sensor reports the results of air quality detection in the form of changes in the analog resistance value on its output pin. The second result is the performance specification of the DHT11 sensor

characteristics with NodeMcu. The DHT11 sensor is a sensor with digital signal calibration that is able to provide temperature and relative humidity information around the sensor [17]. The DHT11 sensor has an analog voltage output.

The third result is software design, software is a physical abstraction that we can possibly talk to hardware machines. Without software, the hardware that has been made cannot function optimally [18]. Software design is carried out with the aim of forming instructions that will be used in the tool work systems. The first results of the system design specifications are the results of characterization data from the MQ-135 sensor and the DHT11 sensor. The MQ-135 sensor is a sensor that reports the results of air quality detection in the form of changes in the analog resistance value at the output pin [19]. To get the results of characterization due to the effect of changes in levels of CO<sub>2</sub> and CO on the output voltage on the sensor. When measuring the output voltage, the sensor is given CO<sub>2</sub> gas and CO gas which varies, for variations in CO<sub>2</sub> gas content 5 variations of gas are given, namely 0.352 moll, 0.704 moll, 1.04 moll, 1.40 moll, 1.72 moll, the output voltage is 4.3V, 4.4V, 4.6V, 4.7V, 4.8V, and the average measurement value of CO<sub>2</sub> gas is 322.92 ppm including the description of hazardous air quality according to the index range. air pollution standards. Variations for CO gas levels are also given 5 variations of gas, namely 15 ppm, 20 ppm, 25,50 ppm, 29 ppm, 33 ppm, the output voltage values are 4.0V, 4.3V, 4.5V, 4.6V, 4.9V, and the average value of the CO gas measurement is 24.07 ppm including the description of good air quality in accordance with the standard index range of air pollution. The DHT11 sensor is a sensor that can detect temperature and humidity. The temperature measurement range of this sensor is 0-50°C and the relative humidity measurement range is 20-90% [20]. When measuring the output voltage of the DHT11 sensor, 5 variations of temperature degrees are given, namely 16°C, 20°C, 24°C, 28°C, 30°C, the sensor output voltage value obtained is 3.9V, 4, 4V, 4.6V, 4.7V, 4.7V, the average temperature measurement value is 25.92 including at normal temperature conditions. Humidity measurements are also given 5 variations of temperature conditions, namely 16°C, 20°C, 24°C, 28°C, 30°C, the voltage values obtained are 4.3%, 4.4%, 4.6%, 4,5%, 4.9%, the relationship between temperature and humidity is that if the temperature increases, the humidity value also increases and vice versa if the temperature decreases, the humidity value will decrease [21-22]. The second and third results on the design specifications are data on the accuracy and accuracy of measuring parameter levels on air quality which are detected by air quality monitoring tools. The results of the analysis obtained that the accuracy of data was 97.78%, while for the accuracy data by repeated measurements 10 times, the measured value was not much different and a relative error of 2.24% was obtained.

Making air quality monitoring has advantages and disadvantages. The presence of air quality monitoring using the IoT-based NodeMcu has solved the problem according to the background that has been described. The problem is that the air quality monitoring tool can only be used at a certain place and at a certain time, so it is difficult to know the air quality in different places. The air quality monitoring tool using the IoT-based NodeMcu was created to solve this problem, namely the air quality monitoring tool can be used anywhere and anytime.

#### 4. Conclusion

The results of the performance specifications of the air quality monitoring system consist of a mechanical system and an electronic sensor system MQ-135 to detect CO<sub>2</sub> levels and CO levels, a

DHT11 sensor to detect temperature and humidity conditions. Supply is used as a voltage source, WiFi is used to activate the tool, software design is used to form instructions that will be used in the tool's work system. The measurement value detected by the sensor is sent to NodeMcu for processing, then sent to Thingspeak display the results of the measurement. When the tool is activated to detect air quality parameters, it can be seen the value of levels of CO<sub>2</sub>, CO and can also be seen the value of the state of temperature and humidity. The results of determining the design specifications of the air quality monitoring system using the IoT-based NodeMcu consist of two parts, namely accuracy and precision. Accuracy is obtained from the comparison of the levels of parameters measured by standard tools with tools that have been made and the percentage of relative accuracy is 97.78%. Accuracy is obtained by measuring repeatedly 10 times, the percentage of relative error is 2.24%.

## References

- [1] Andrizar, Putri Indah Yani, & Yul Antonisfia. (2020). "Monitoring Dan Kontrol Kadar CO<sub>2</sub> Dalam Ruangan Berbasis Sistem Penciuman Elektronik". *Jurnal Seminar Nasional Terapan Riset Inovatif (SENTRINOV) Series: Engineering and Science*, 6(1), 388-395.
- [2] Jaya, A. I. (2011). "Mencari Perluasan Model Dinamik Unsur-Unsur Utama Iklim". *Jurnal Ilmiah Matematika dan Terapan*, 8(1).
- [3] Astuti, I. A. D., & Firdaus. (2017). "Analisis Kandungan CO<sub>2</sub> Dengan Sensor Dan Berbasis Logger Pro Di Daerah Yogyakarta". *Jurnal Inovasi Pendidikan Fisika dan Riset Ilmiah*, 1(1), 5-8.
- [4] IPCC Climate Change. (2007). "The Physical Science Basis Contribution of Working Group I to the Fourth Assessment Report of the Intergovernmental Panel on Climate Change".
- [5] Rahim, R., dkk. (2016). "Karakteristik Data Temperatur Udara Dan Kenyamanan Termal di Makassar". e-Proceeding Temu Ilmiah IPLBI.
- [6] Fauziah, D. A., Rahardjo, M., & Nikie A. Y. D. (2017). "Analisis Tingkat Pencemaran Udara Di Terminal Kota Semarang". *Jurnal Kesehatan Masyarakat*, 5(5).
- [7] Virdaus, M. S. S., & Eko Ihsanto. (2021). "Rancang Bangun Monitoring Dan Kontrol Kualitas Udara Dengan Metode Fuzzy Logic Berbasis Wemos". *Jurnal Teknologi Elektro*, 12(1):22-28.
- [8] Prasetyo, Dwi, Ibrahim, Lamada, Wilma, Nurul, Adzillah. 2021. "Implementasi Monitoring Kualitas Udara Menggunakan MQ-7 dan MQ-131 Berbasis Internet of Things". *Jurnal Rekayasa dan Teknologi Elektro*, Vol. 15 (3).
- [9] Tobari, MC Kota Padang. (2019). "ISPU Kota Padang Capai Nilai 67." Diakses dari: <https://infopublik.id/kategori/nusantara/375249/ispu-kota-padang-capai-nilai> pada 15 November 2021.
- [10] Amsar, Khairuman, & Marlina. (2020). "Perancangan Alat Pendeteksi CO<sub>2</sub> Menggunakan Sensor MQ-2 Berbasis Internet Of Things". *Jurnal Manajemen Informatika & Komputerisasi Akuntansi (METHOMIKA)*, 4(1), 73-79.

- [11] Faradilla, C. (2020). “Monitoring Dan Kandungan Gas Udara Kering CO, CO<sub>2</sub> Pada Ruangan Tertutup Berbasis Mikrokontroler”. Tugas Akhir. Padang: Jurusan Teknik Elektro.
- [12] Cooper, W. D. (1999). “Instrumentasi Elektronika dan Teknik Pengukuran”. Jakarta: Erlangga.
- [13] Mulyanah, Elwin, & Hellyana, M. C. (2015). “Perancangan Dan Pembuatan Alat Pengering Kerupuk Otomatis Menggunakan Mikrokontroler atmega 16”. Jurnal Evolusi, 3(2), 45.
- [14] Susilawati, Helfy, Ade, Rukmana, Jonhari, Apip. (2020). "Rancang Bangun Prototype Monitoring Kadar Gas CO, CO<sub>2</sub>, CH<sub>4</sub> Berbasis Mikrokontroler Atmega 328P di Ruangan Laboratorium". Vol 11 (1)
- [15] N, Rosman Andi. (2017). “Perancangan Power Supply 4.5 Dan 11.5 Volt Menggunakan Rangkaian Regulator Zener Follower”. Jurnal Scientific Pinisi, 3(1), 55-59.
- [16] Azrol Bin Azahar, M., Shamian Zainal, M., Shahidah Mohd Shah, N., Md Nor, D., Anuar Hamzah, S., & Mohamed, M. (2020). IoT-Based Air Quality Device for Smart Pollution Monitoring. *Progress in Engineering Application and Technology*, 1(1), 284-295. <https://doi.org/10.30880/peat.2020.01.01.031>.
- [17] Jaber, A. A., Al-Mousawi, F. K. I., & Jasem, H. S. (2019). Internet of Things based industrial environment monitoring and control: A design approach. *International Journal of Electrical and Computer Engineering*, 9(6), 4657–4667. <https://doi.org/10.11591/ijece.v9i6.pp4657-4667>
- [18] Kristiyana, S., & Rinaldi, A. (2020). Air Quality Monitoring System in Thingspeak-Based Applications Using Internet of Things (IOT). *WSEAS TRANSACTIONS ON COMPUTER RESEARCH*, 8, 34–38. <https://doi.org/10.37394/232018.2020.8.6>
- [19] Murad, S. A. Z., Bakar, F. A., Azizan, A., & Shukri, M. A. M. (2021). Design of Internet of Things Based Air Pollution Monitoring System Using Thingspeak and Blynk Application. *Journal of Physics: Conference Series*, 1962(1). <https://doi.org/10.1088/1742-6596/1962/1/012062>
- [20] Nasution, T. H., Muchtar, M. A., & Simon, A. (2019). Designing an IoT-based air quality monitoring system. *IOP Conference Series: Materials Science and Engineering*, 648(1). <https://doi.org/10.1088/1757-899X/648/1/012037>